

FlowCon SM 2"-6"

Dynamic Self Balancing Control Valve



SPECIFICATIONS

Pressure rating:	4000 kPa / 580 psi
Temperature rating, media:	-20°C to +120°C / -4°F to +248°F
Temperature rating, ambient:	-10°C to +50°C / +14°F to +122°F
Material:	
- Diaphragm:	Hydrogenated acrylonitrile-butadiene-rubber
- Body:	Ductile iron ASTM A536-65T, Class 60-45-18
- O-rings:	EPDM
- Internal metal components:	Stainless steel
End connection:	Universal flange connections which can be used with both ISO and ANSI Flanges and mounting kits are not supplied by FlowCon ¹
Body tappings:	1/4" ISO
Maximum close off pressure:	600 kPa / 87 psi
Maximum operational ΔP :	400 kPaD / 58 psid
Flow rate range:	1.48-29.5 l/sec / 23.4-468 GPM

Note1: 2x16mm studs and 4x16mm bolts with nuts are supplied with SM.3.x.x.x.

DIMENSIONS AND WEIGHTS (NOMINAL) (measured in inches unless noted)

Model no.	Size	L	H1	H2	Weight ² (lbs.)
SM.3.X	2"	8.82	9.92	3.74	33.1 ³
	2 1/2"				
	3"				
SM.4.X	3"	12.6	11.5	5.31	68.3
	4"				70.5 (SM.4.3 only)
SM.5.X	5"	16.6	13.5	7.09	134.5
	6"				

Note 2: Weight includes valve and actuator.

Note 3: Including studs, bolts and nuts provided with valve.

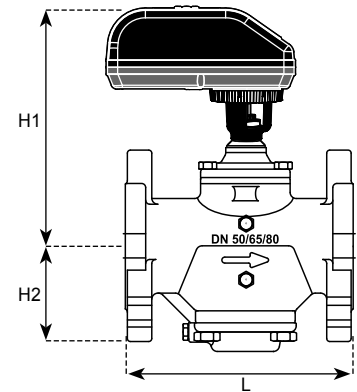

MODEL NUMBER SELECTION⁴

Insert valve body size:

3=50-80mm, 2"-3" **4**=80-100mm, 3"-4" **5**=125-150mm, 5"-6"

Insert dP control range:

0=35-400 kPaD, 5.1-58 psid (SM.3 only)
1=35-400 kPaD, 5.1-58 psid
2=60/80-400 kPaD, 8.7/11.6-58 psid
3=60-400 kPaD, 8.7-58 psid (SM.4 only)

Insert p/t plug requirements:

B=p/t plugs (standard)

Insert actuator selection:

3=display (SM.0.0.0.3) **4**=display and failsafe (SM.0.0.0.4) **5**=display and BACnet (SM.0.0.0.5) **6**=display, BACnet and failsafe (SM.0.0.0.6)

Example: SM.3.1.B.4=SM 2"-3" body for 5.1-58 psid with p/t plugs and failsafe actuator.

Note 4: Model no. and pressure range are indicated on label affixed to body.

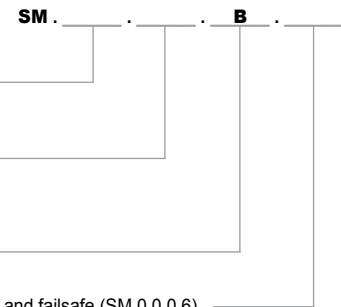

ACTUATOR SPECIFICATIONS⁵

FlowCon SM.0.0.0.3, SM.0.0.0.4, SM.0.0.0.5 (with BACnet) and SM.0.0.0.6 (with BACnet) actuators

Supply voltage:	24V AC/DC
Power consumption:	12VA
Frequency:	50/60 HZ
Control input:	0-10V DC, 2-10V DC, 0-20mA, 4-20mA, 2-position or 3-point floating
Feedback position output:	Automatic match of control input, 0-10V DC, 2-10V DC or 4-20mA
Turn time:	190 seconds (from closed to fully open valve)
Electrical connection:	5 wires 22 AWG halogen free cable, 3.28 ft For BACnet versions another 3 wires 22 AWG halogen free cable, 3.28 ft
Direction of rotation:	Bi-directional
Humidity rating:	5 to 95% RH non condensing
Housing material:	UL94 V0-rated plastic
Housing insulation:	IP54 including up-side-down mounting
Programming:	External programming of all settings, interface of buttons and display
Calibration:	Automatic calibration at startup
Valve - actuator coupling:	Easy snap coupling
BACnet device profile:	BACnet Application Specific Controller (B-ASC) type server
BACnet protocol:	BACnet Master Slave/Token passing (MS/TP)
BACnet baud rates supported:	9600, 19200, 38400 and 76800
BACnet services (BIBBS) supported:	DS-RP-B, DS-WP-B, DM-DDB-B, DM-DOB-B and DM-DCC-B.

Note 5: FlowCon warranty is voided using other actuators than supplied or recommended by FlowCon International A/S.

FLOW RATE TABLE

Model no.	Valve size		Control range		Minimum setting			Maximum setting			Shut-off leakage
	mm	inch	kPaD	psid	l/sec	l/hr	GPM	l/sec	l/hr	GPM	
SM.3.0	50	2"	35-400	5.1-58	1.48	5310	23.4	4.16	15000	65.9	Leakage<0.2% of Kvs, Kvs=24 m³/hr
	65	2 1/2"									
	80	3"									
SM.3.1	50	2"	35-400	5.1-58	2.57	9240	40.7	7.15	25700	113	Leakage<0.2% of Kvs, Kvs=39.5 m³/hr
	65	2 1/2"									
	80	3"									
SM.3.2	50	2"	80-400	11.6-58	3.55	12800	56.3	9.89	35600	157	Leakage<0.2% of Kvs, Kvs=58.3 m³/hr
	65	2 1/2"									
	80	3"									
SM.4.1	80	3"	35-400	5.1-58	3.49	12600	55.4	9.38	33800	149	Leakage<0.2% of Kvs, Kvs=89 m³/hr
	100	4"									
SM.4.2	80	3"	60-400	8.7-58	4.73	17000	75.0	14.2	51000	225	Leakage<0.2% of Kvs, Kvs=89 m³/hr
	100	4"									
SM.4.3	80	3"	60-400	8.7-58	3.68	13300	58.3	20.2	72700	320	Leakage<0.2% of Kvs, Kvs=132.3 m³/hr
	100	4"									
SM.5.1	125	5"	35-400	5.1-58	6.48	23300	103	23.3	83800	369	Leakage<0.2% of Kvs, Kvs=132.3 m³/hr
	150	6"									
SM.5.2	125	5"	60-400	8.7-58	7.10	25600	113	29.5	106000	468	Leakage<0.2% of Kvs, Kvs=132.3 m³/hr
	150	6"									

Accuracy: Greatest of either $\pm 5\%$ of controlled flow rate or $\pm 2\%$ of maximum flow rate.

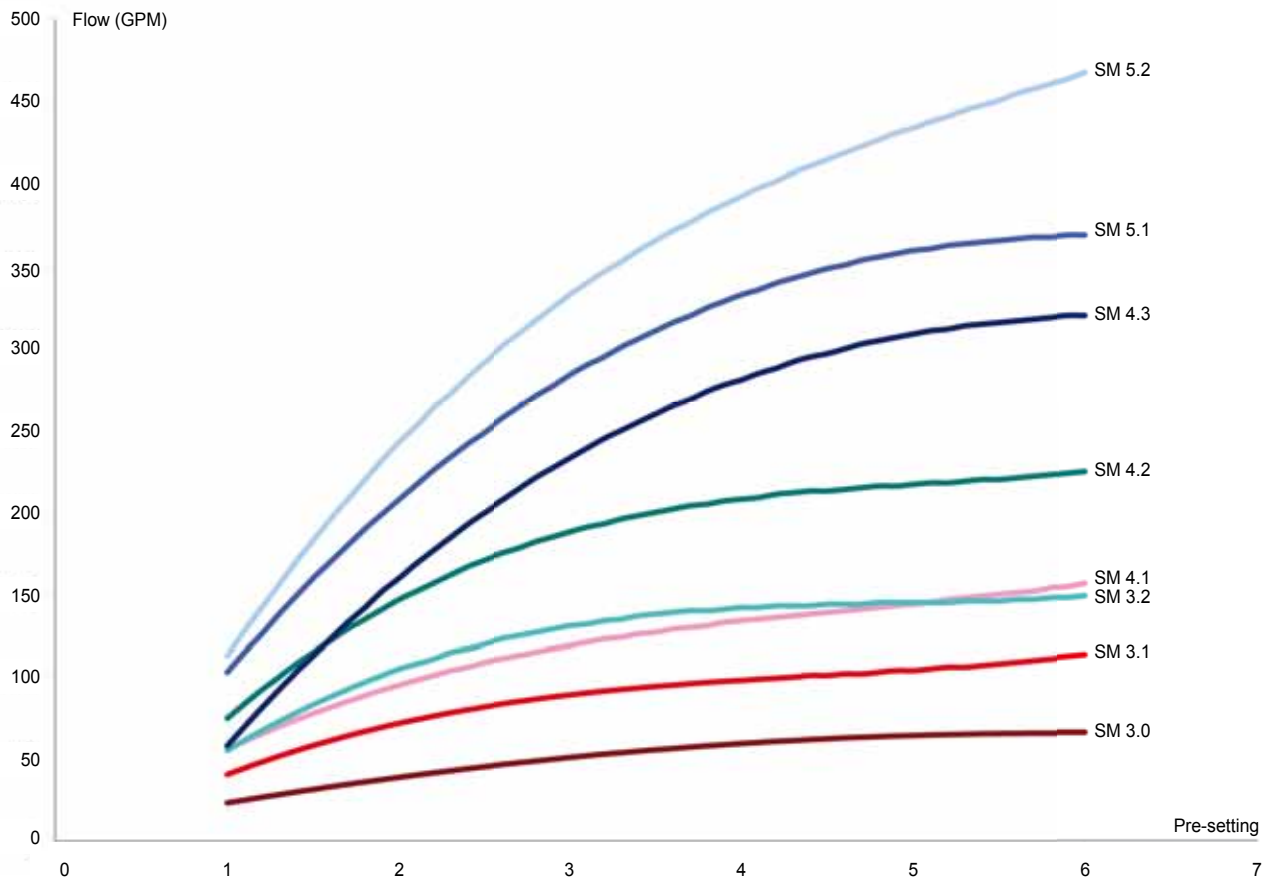

GENERAL DESCRIPTION

Model no.	Flange size (inch)	ASME B16.5 weld neck flanges		ASME B16.5 slip on flanges		Flange size (mm)	EN1092-1 ⁶				EN1092-1 ⁷			
		Class 150	Class 300	Class 150	Class 300		PN10	PN16	PN25	PN40	PN10	PN16	PN25	PN40
SM.3.x	2	-	✓	-	✓	50	✓	✓	✓	✓	✓	✓	✓	✓
	2 1/2	✓	✓	✓	✓	65	✓	✓	✓	✓	✓	✓	✓	✓
	3	✓	✓	-	-	80	✓	✓	✓	✓	-	-	-	-
SM.4.x	3	✓	✓	✓	✓	80	✓	✓	✓	✓	✓	✓	✓	✓
	4	✓	✓	-	-	100	✓	✓	✓	✓	-	-	-	-
SM.5.x	5	✓	✓	✓	✓	125	✓	✓	✓	✓	✓	✓	✓	✓
	6	✓	-	-	-	150	✓	✓	✓	✓	-	-	-	-

Note 6: Type 02 and 35/36/37 (loose plate flange with welding neck / pressed collar with long neck / pressed collar) or Type 04 and 34 (loose plate flange with weld-neck collar) or Type 11 with flange facing A/B (weld-neck flange with flat face or raised face).

Note 7: Type 12 with flange facing A/B (hubbed slip-on flange with flat face or raised face).

GENERAL DESCRIPTION

The SM Series are self balancing dynamic flow control valves that are pressure independent, two-way, modulating to accept digital or analog input signals. The valves accept 2-10V DC, 4-20mA, digital 2-position or digital 3-point floating input signals. Each valve has an adjustable maximum flow rate setting to enable flow limitation and balancing to the coils or zones that the valves are controlling.

All SM actuators are microprocessor based with a self-calibrating feature.

The SM valve is of the wafer style for fitting between flanges. They are available in three different valve bodies for flange connections.

GENERAL SPECIFICATIONS

1. PRESSURE INDEPENDENT DYNAMIC CONTROL VALVE FLOWCON SM

- 1.1. Contractor shall install dynamic control valves where indicated in drawings.
- 1.2. Valve shall be an electronic, dynamic, modulating, 2-way pressure independent control device.
- 1.3. Pressure independent dynamic control valve shall accurately control flow, independent of system pressure fluctuation.
- 1.4. Maximum flow setting shall be adjustable to 51 different settings within the range of the valve size.
- 1.5. Valve and actuator coupling shall have snap couplings for fast mounting and demounting.

2. VALVE ACTUATOR

- 2.1. Actuator housing shall be rated to IP54 including up-side-down mounting.
- 2.2. Actuator shall be driven by a 24V AC/DC motor and shall accept 0-10V DC, 2-10V DC, 0-20mA, 4-20mA, 2-position or 3-point floating electric input signal.
- 2.3. Actuator shall be capable of providing same as input, 4-20mA, 0-10V DC or 2-10V DC feedback signal to the control system.
- 2.4. Automatic calibration of valve position shall be standard.
- 2.5. Actuator shall include display and buttons for external programming of all settings.
- 2.6. External display of current valve flow, maximum valve flow, input signal, feedback signal and operational direction shall be standard.
- 2.7. Optional fail safe system to power valve to either open (max. setting) or closed position from any position in case of power failure shall be available.
- 2.8. Optional BACnet connection for remote setting and control of actuator shall be available.

continues...

GENERAL SPECIFICATIONS (continued)

3. VALVE HOUSING

- 3.1. Valve housing shall consist of ductile iron ASTM A536-65T, Class 60-45-18 rated at no less than 580 psi static pressure and +248°F.
- 3.2. Valve housing shall be permanently marked to show direction of flow.
- 3.3. Valve housing shall be for installation between flanges.
- 3.4. Dual pressure/temperature test plugs for verifying accuracy of flow performance shall be provided for all valve sizes.
- 3.5. Identification tags shall be available for all valves; tags shall be indelibly marked with part number, production date and pressure differential range. Tags shall be of aluminum and in size 2" x 1".

4. FLOW REGULATOR / AUTOMATIC BALANCING UNIT

- 4.1. Flow regulation unit shall be manufactured of stainless steel and hydrogenated acrylonitrile-butadiene-rubber and shall be capable of controlling flow within $\pm 5\%$ rated flow rate or $\pm 2\%$ of maximum flow rate.
- 4.2. Flow regulation unit shall be accessible for change-out or maintenance.

APPLICATION AND SCHEMATIC EXAMPLE

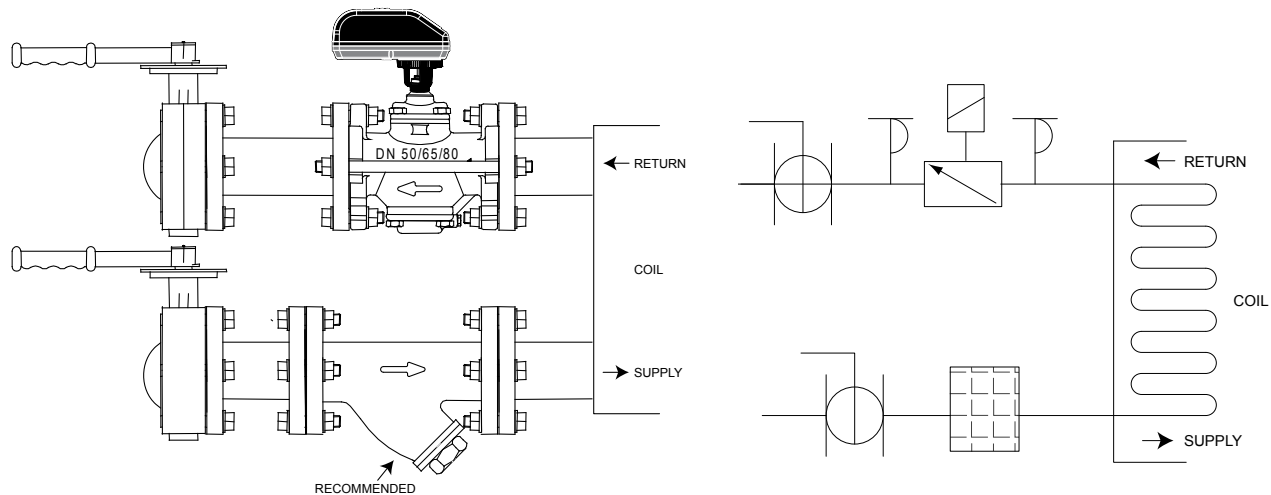

UPDATES

For latest updates please see www.flowcon.com

FlowCon International A/S can accept no responsibility for possible errors in any printed material. All rights reserved.